

RUBBER EXPANSION JOINT TEGUFLEX® PDW RED-WHITE EPDM ACS



ISO 9001

BUREAU VERITAS
Certification



BUREAU
VERITAS
PED 97 / 23 / CE



Size : DN 25 to 300
Ends : Flanges PN10/16
Min Temperature : - 25°C
Max Temperature : + 90°C
Max Pressure : 16 Bars up to DN150, 10 bars over
Specifications : Absorb vibrations and noise
Linear and angular compansion
Inner Tube EPDM ACS

Materials : Dichromate zinc plated steel flanges

RUBBER EXPANSION JOINT TEGUFLEX® PDW RED-WHITE EPDM ACS
SPECIFICATIONS :

- Absorb vibration, noises and expansion
- Linear and angular compansion
- Inner tube EPDM ACS
- 130 mm length
- Dichromate zinc plated steel swiveling flanges
- PN10/16 up to DN150, PN10 over
- AISI 316 flanges on request
- AISI 316 Ti vacuum ring on request (Ref.9815050 to 9815300)
- Inner liner PTFE on request (movements allowed by the expansion joints are then reduced by 50 % and pressure max is 6 bars)
- Bursting pressure >50 bar at 20°C
- Test pressure 25 bar at 20°C

USE :

- Drinkable water
- Not advisable for hydrocarbons, greasy product and abrasive products
- Min and max temperature Ts : - 25°C to + 90°C
- Max pressure Ps : 16 bars (6 bars with PTFE lining) up to DN150, 10 bars over

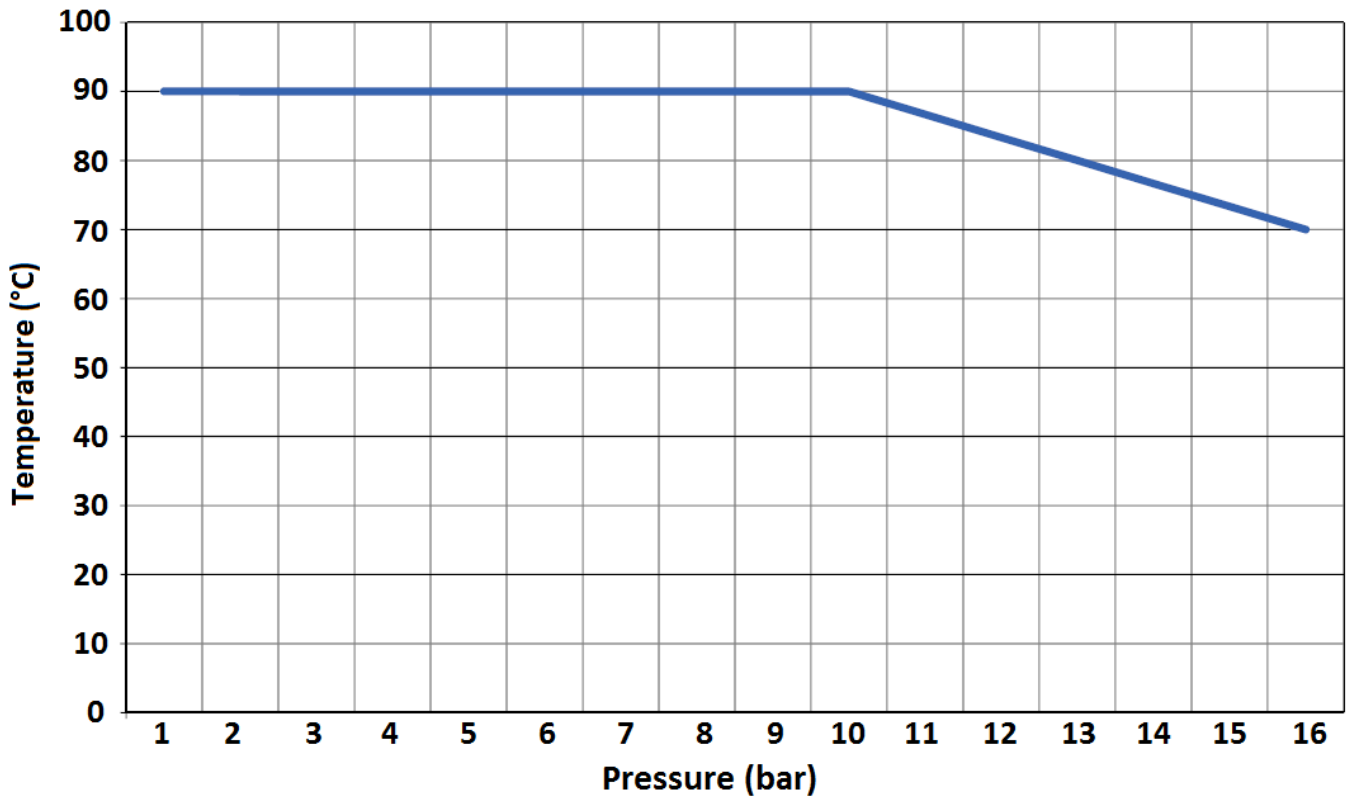
PRESSURE / TEMPERATURE GRAPH (STEAM EXCLUDED) :

MAXIMUM VACUUM :

DN	25/32	40	50	65	80	100	125	150	200	250	300
Vacuum (bar)	0.8	0.8	0.7	0.6	0.5	0.5	0.4	0.3	0.3	0.2	0.2

RUBBER EXPANSION JOINT TEGUFLEX® PDW RED-WHITE EPDM ACS

RANGE :

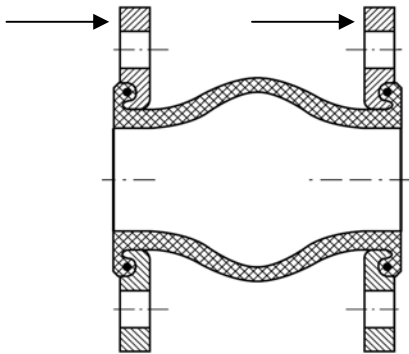
- EPDM ACS expansion joint with dichromate zinc plated steel flanges PN10/16 from DN 25 to DN 150, PN10 over **Ref. 1561**
- On Request :



- AISI 316 flanges

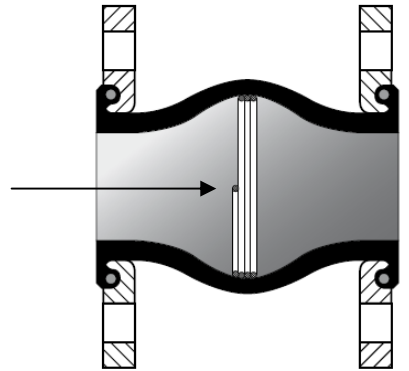

- AISI 316 Ti vacuum ring (vacuum up to 1 bar) Ref.9815050 to 9815300

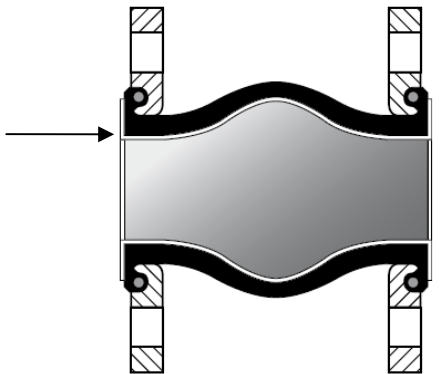

- Inner liner PTFE (movements allowed by the expansion joints are then reduced by 50 % and pressure max is 6 bars)

RUBBER EXPANSION JOINT TEGUFLEX® PDW RED-WHITE EPDM ACS

MATERIALS :

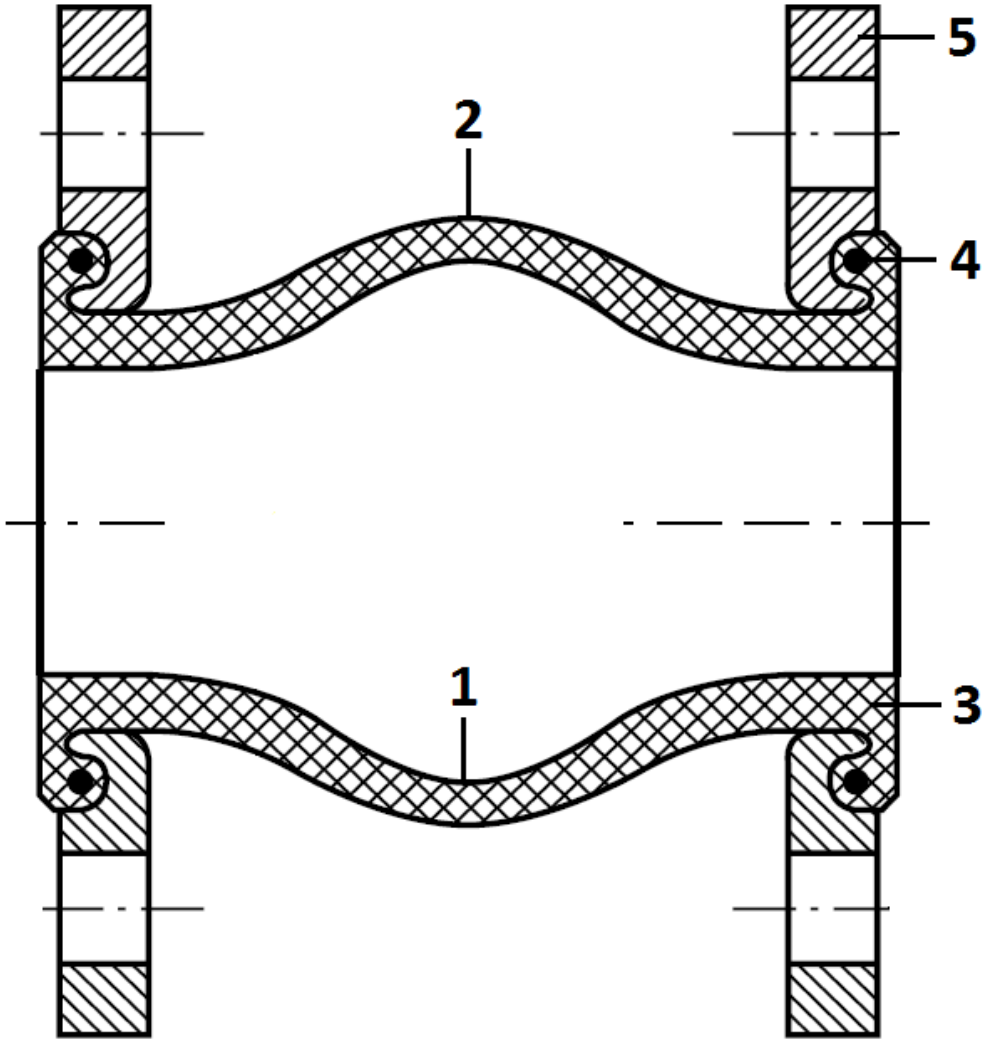

Item	Designation	Materials
1	Inner tube	EPDM ACS
2	Outer cover	EPDM
3	Reinforcement	Synthetic textile
4	Brace	Carbon steel
5	Swiveling flanges	Dichromate zinc plated steel

RUBBER EXPANSION JOINT TEGUFLEX® PDW RED-WHITE EPDM ACS

SIZE (in mm) :

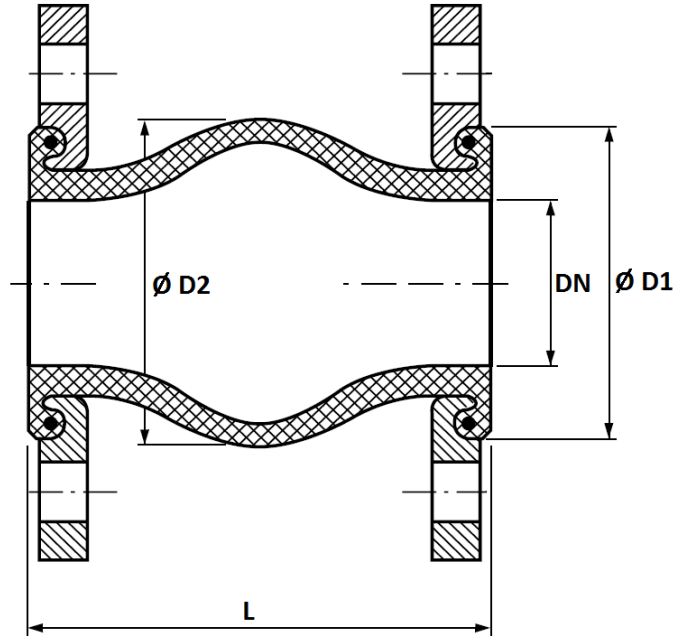

Ref.	DN	25/32	40	50	65	80	100	125	150	200	250	300
1561	L	130	130	130	130	130	130	130	130	130	130	130
	Ø D1	72	80	90	105	120	140	165	190	240	290	340
	Ø D2	77	85	95	110	125	145	170	195	245	295	345
	Weight (Kg)	2.8	3.3	3.7	4.8	5.3	6.2	8.2	11.2	16.8	21.6	30.1

FLANGES SIZE (in mm) :

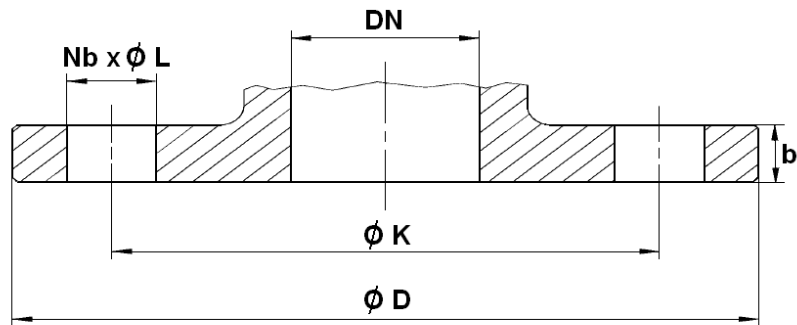

DN	25	32	40	50	65	80	100	125	150	200	250	300
Ø D	115	140	150	165	185	200	220	250	285	340	395	445
Ø K	85	100	110	125	145	160	180	210	240	295	350	400
Nb x Ø L	4x14	4 x 18	4 x 18	4 x 18	4 x 18	8 x 18	8 x 18	8 x 18	8 x 22	8 x 22	12 x 22	12 x 22
b	13.8	13.8	14	14.1	14.4	14.8	15.2	16	17.8	20.2	22.6	26.5

RUBBER EXPANSION JOINT TEGUFLEX® PDW RED-WHITE EPDM ACS

MOVEMENTS (in mm) :

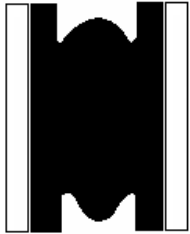

Compansion

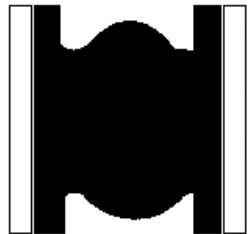

Expansion

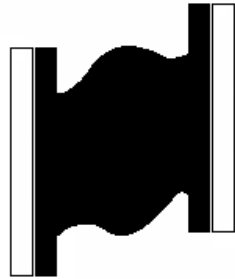

Lateral

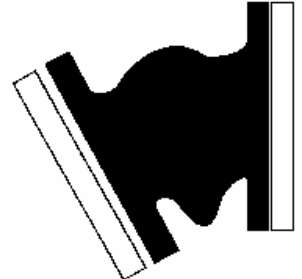

Angular

DN	25-50	65	80	100	125	150	200	250	300
Compansion	30	30	30	30	30	30	30	30	30
Expansion	20	20	20	20	20	20	20	20	20
Lateral	20	20	20	20	20	20	20	20	20
Angular	35°	30°	30°	25°	25°	15°	15°	10°	10°

Maximum movements can't be applied simultaneously.
For example, with an expansion of 15mm, the maximum lateral movement will be 8 mm :

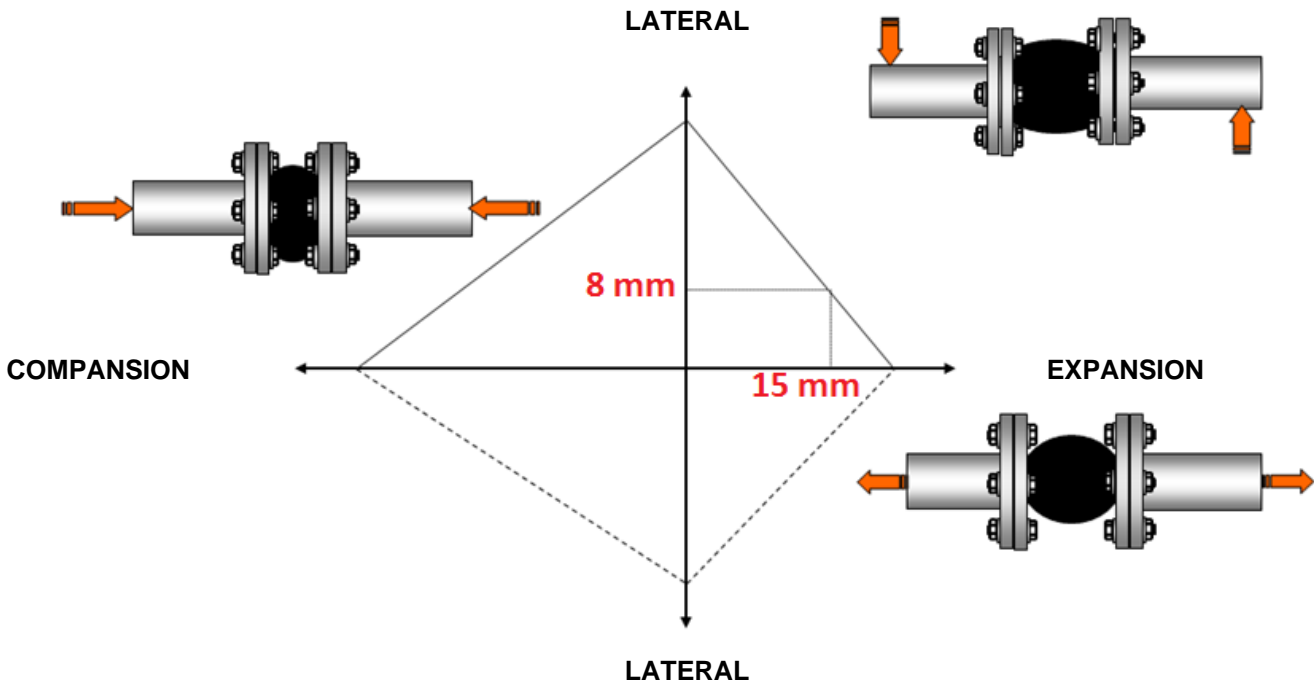

RUBBER EXPANSION JOINT TEGUFLEX® PDW RED-WHITE EPDM ACS

MARKING :



STANDARDS :

- Fabrication according to ISO 9001 : 2008
- DIRECTIVE 97/23/CE : CE N° 0056
Risk category III Module H
- Flanges according to EN 1092-1 PN10/16
- French water agreement **ACS N° 15 MAT LY 018**

ADVICE : Our opinion and our advice are not guaranteed and SFERACO shall not be liable for the consequences of damages.
The customer must check the right choice of the products with the real service conditions.

RUBBER EXPANSION JOINT TEGUFLEX® PDW RED-WHITE EPDM ACS
INSTALLATION INSTRUCTION 1/4 :
Key factors for installation

Rubber expansion joints are supplied ready for installation. Following advises are However to be taken into consideration in order to obtain a good performance and prolonged service life of the expansion joint.

Fixed points

An expansion joint acts as a piston by the forces arising from the internal pressure. To prevent the pipes from damage they are to be properly anchored in order to take care of these reaction forces (Fr). The reaction force of an expansion joint is calculated by the following formula:

$$Fr = A \times P \times 0,01$$

Fr = Reaction force in kN.

A = effective cross sectional area in cm².

P = actual pressure in bar or kp/cm².

Installation

The turnable metal flanges make installation easier and eliminate twist.
 The low inherent rigidity of expansion joints make for easier accommodation of installation dimensions. The expansion joints shall be easily accessible and open to regular supervision.
 It is recommended to let the expansion joints work in compression rather than stretching.
 Torsion is not permitted. Check the permissible movements, temperature, pressure and proper rubber quality before installation!

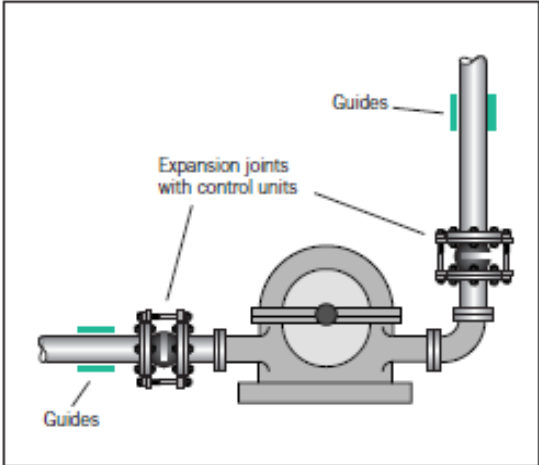

Pressure-restrained expansion joint on pump (with tie bar). Absorb vibrations and thus relieve pressure on the machine housing.

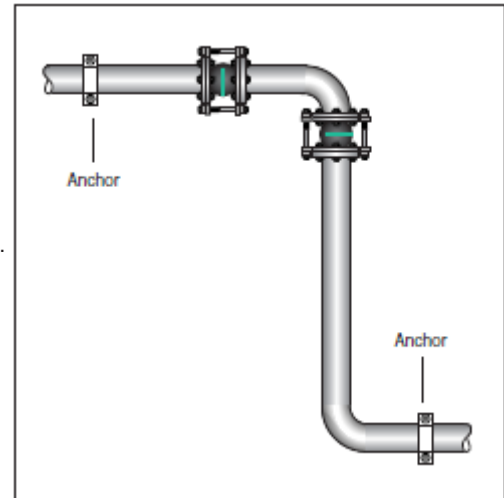

Arrangement with lateral expansion joints

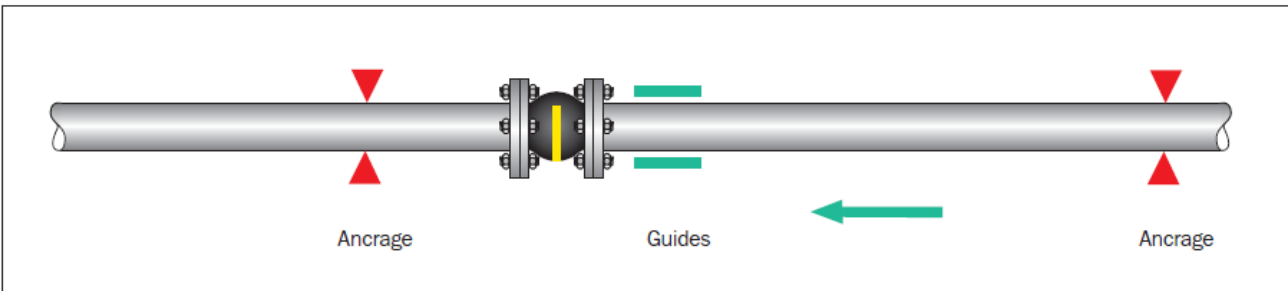

RUBBER EXPANSION JOINT TEGUFLEX® PDW RED-WHITE EPDM ACS

INSTALLATION INSTRUCTION 2/4 :

Expansion joint are designed for the absorption of previously specified movements under specific pressure and temperature conditions. So that the maximum service life is achieved, the following items must be observed during installation.

- Prior to fitment of the compensator it must be ensured that :
 - The route of the pipeline is straight - The expansion tallies with that of the chosen compensator
 - The expansion tallies with that of The chosen compensator
 - The fixes points are dimensionned so that they can absorb the reaction forces and stiffness rate that arise during use.
 - The pipeline is limited by fixed points
 - The distance between compensator and bearing may be a maximum of 3 times the pipe diameter. Place only one compensator between 2 bearings.
- Each pipe elbow must be fixed by support, specially if compensator is mounted with limiters. Fixed bearings are necessary because compensator is submitted to expansion when it is under pressure.
- Expansion joint must not be painted and heat-insulated. It must be protected from bad weather and solar radiation.
- During assembly operation, make sure screws are oriented according to the graph out below :

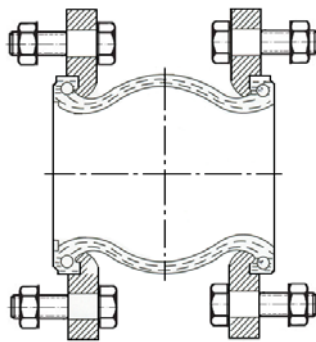

- Please apply the following stages order :
 - a) Fixed points for above pipeline
 - b) Fixed points for down pipeline
 - c) Compensator mounting

- Installation layout :

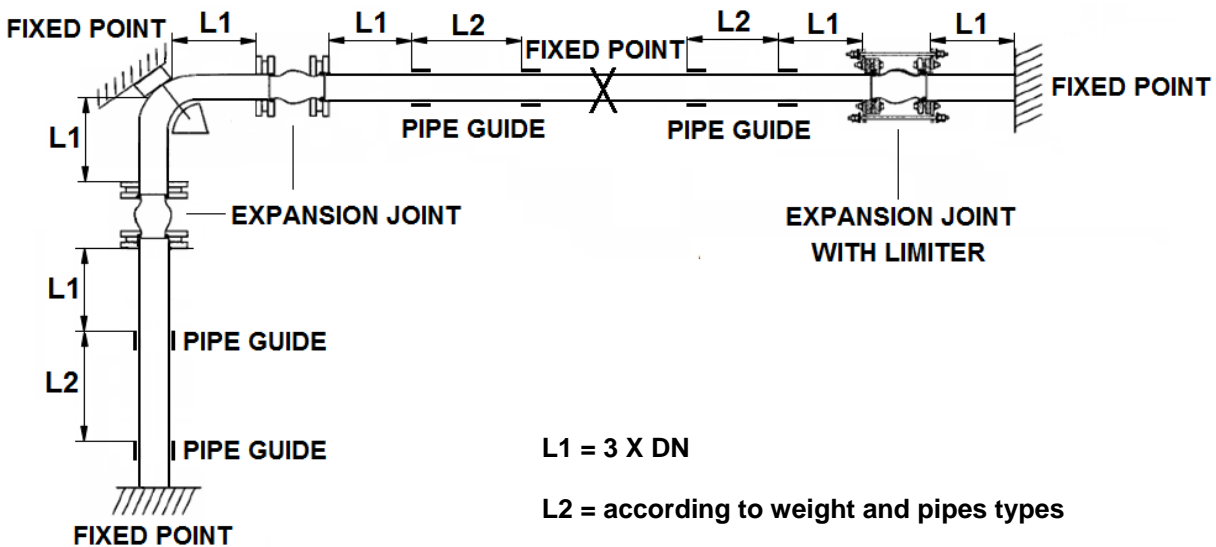

RUBBER EXPANSION JOINT TEGUFLEX® PDW RED-WHITE EPDM ACS
INSTALLATION INSTRUCTION 3/4 :

- Check that the compensator is not subjected to the weight of the pipeline. The installation length must agree with the installation gap. The compensator must never be twisted. It is recommended that specific characteristics be observed during maintenance :
 - The compensator must never be painted or recovered by heat insulation
 - The tightness of the bolts must be checked often.
 - The flanges must be perfectly cleared

- Use limiters : When the working pressure can exceed the following values :
 - Up to DN100 : 10 bars
 - From DN125 to DN250 : 9 bars
 - From DN300 to DN350 : 6 bars
 - From DN400 to DN600 : 3 bars
 - When there is some risk of high pressure (pump starting) or high temperature.

NOTA : The life of compensator can vary because of working conditions (fluids, pressure, temperature), that is why it is necessary to check it regularly.

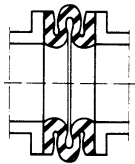
WRONG INSTALLATION :

Excessive compansion

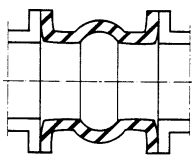

Excessive expansion

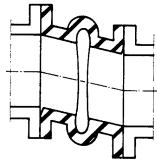

Cutting too important

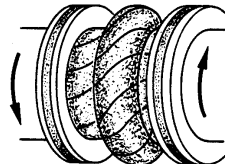

Torsion

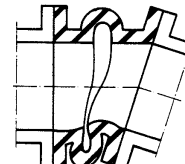

Important compansion and angular deviation

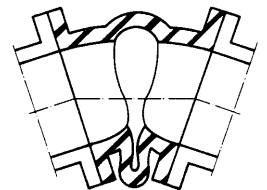

Angular deviation too important

RUBBER EXPANSION JOINT TEGUFLEX® PDW RED-WHITE EPDM ACS

INSTALLATION INSTRUCTION 4/4 :

Mounting

- In order to provide the movement capabilities indicated in the technical specifications, the assembly bolts should be mounted with bolts heads towards expansion joint body. (1)
- If this is for any reason impossible, ensure that the threaded bolts project as little as possible (no more than 2 or 3 mm) to avoid damage to the body.
- Tightening must be progressive and crosswise in diagonal sequence with bolting pressure evenly distributed.
- The design of the expansion joints secures a sealing to the counter flange. That is why no sealing gasket is required.

Note: If the bolts and nuts are tightened too strongly, the sealing face might be crushed causing improper function!

Counter flanges

It is very important for the safe operating and life expectancy of the expansion joint to make a proper installation of the counter flanges(Fig. 2 to 5). The sealing face of the counter flange must be machined smooth and cover most of the rubber sealing face (or at least 60%) to ensure a good sealing (Fig.2).

Precaution

Do not paint or lubricate rubber parts of expansion joints!
When welding work is to take place the bellow has to be protected from welding heat and sparks!

Right

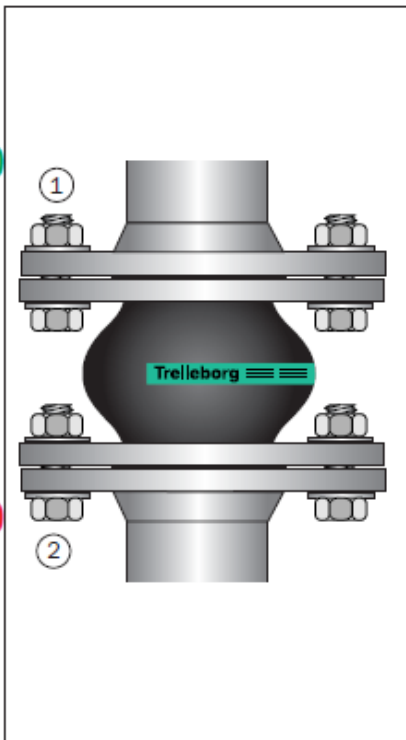

Fig. 1

Wrong

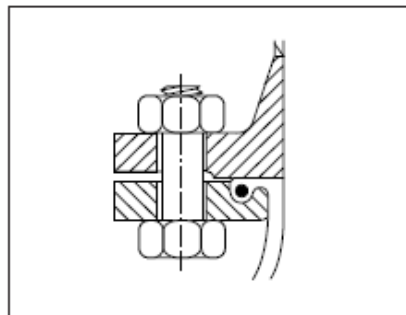

Fig. 2 Flange provided with smooth sealing surface.

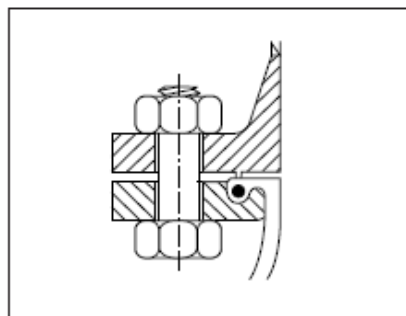

Fig. 3 Do not use flange with tongue or groove which will damage the rubber.

Right

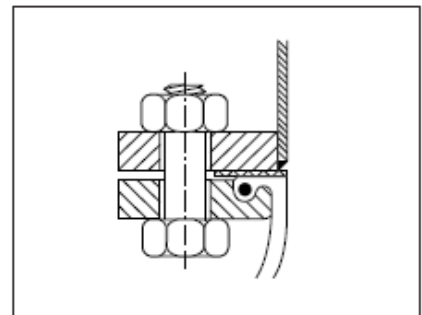

Fig. 4 Flange provided with flat sealing gasket to protect the rubber surface.

Wrong

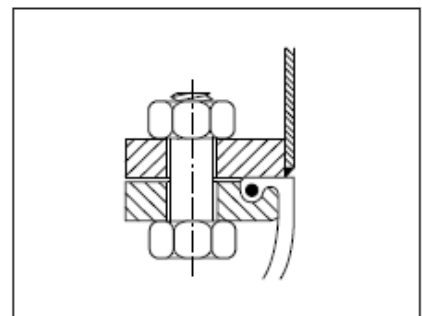

Fig. 5 Sharp edge pipe ends will damage the rubber face.